



RF Inductor

SMD Wirewound Inductors Chip Open-Type - WL Series / 绕线贴片电感

Wirewound Chip Inductor Features

- Wire wound Ceramic Construction Provide High SRFs.
- Ultra-compact Inductors Provide Exceptional Q Values.
- Low profile , High Current are Available.
- Miniature SMD Chip Inductor for Fully Automated Assembly.
- Outstanding Endurance from Pull-up Force, Mechanical Shock and Pressure.
- Tighter Tolerance of $\pm 2\%$.
- Smaller Size of 0402 (1005).



Wirewound Chip Inductor Applications

- Cellular Phone (CDMA/GSM/PHS), Cordless Phone (DECT/CT1CT2)
- Remote Control, Security System, Wireless PDA
- TCWLL, Wireless LAN / Mouse / Keyboard / Earphone
- VCO, RF Module & Other Wireless Products, Base Station, RepeaterGPS Receiver
- CATV Filter, Tuner, Cable Modem / XDSL Tuner, Set Top Box
- USB 2.0, IEEE 1394.

Wirewound Chip Inductor Dimensions (unit: mm)

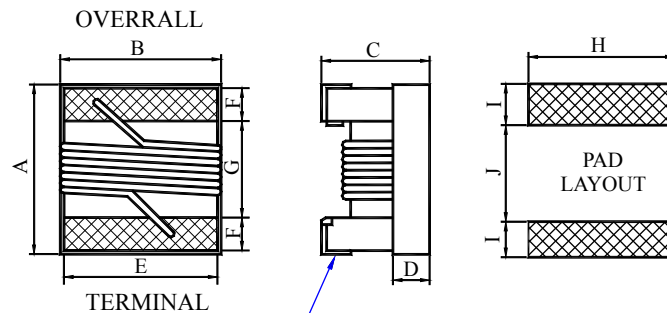

TERMINAL WARP/ROUND: APPROX.0.007"/0.18mm BOTH ENDS

Series	A Max.	B Max.	C Max.	D Ref.	E	F	G	H	I	J
Standard										
TCWL08	2.92	2.79	2.03	0.65	2.03	0.51	1.52	2.54	1.02	1.27
TCWL06	3.56	2.16	1.52	0.50	1.20	0.50	2.20	1.93	1.02	1.78
TCWL05	2.29	1.73	1.52	0.51	1.27	0.44	1.02	1.78	1.02	0.76
TCWL03	1.80	1.12	1.02	0.38	0.76	0.33	0.86	1.02	0.64	0.64
TCWL02	1.27	0.76	0.61	0.15	0.51	0.23	0.56	0.66	0.50	0.46
Low Profile										
TCWL08	2.92	2.79	1.40	0.65	2.03	0.51	1.52	2.54	1.02	1.27
TCWL05	2.29	1.73	1.03	0.51	1.27	0.44	1.02	1.78	1.02	0.76
High Current / High Q										
TCWL08	2.92	2.79	2.03	0.65	2.03	0.51	1.52	2.54	1.02	1.27
TCWL05	2.29	1.73	1.52	0.51	1.27	0.44	1.02	1.78	1.02	0.76
TCWL03	1.80	1.12	1.02	0.38	0.76	0.33	0.86	1.02	0.64	0.64



RF Inductor

► Color Coding - Wirewound Chip Inductors

0603 / 0805/1206/1008 Series (0402 Series is No Color Coding)

Because of small sizes, these parts are marked with a single color dot.

The inductance value represented by the dot is shown on the data page for each series.

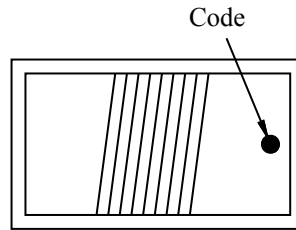

COLOR CODING

► Standard Electrical Specifications for 0402 Wire Wound Chip Inductors / Standard

Part Number	Inductance(nH) @ 250MHz	Tolerance (%)	Q (min)	SRF (GHz)(min)	DCR(Ω) (max)	IDC (mA)	900MHz		1.7GHz	
							L	Q	L	Q
TCWL02*T1N0	1.0	10	16	12.70	0.04	1360	1.02	77	1.02	69
TCWL02*T1N9	1.9	10,5	16	11.30	0.07	1040	1.72	68	1.74	82
TCWL02*T2N0	2.0	10,5	16	11.10	0.07	1040	1.93	54	1.93	75
TCWL02*T2N2	2.2	10,5	19	10.80	0.07	960	2.19	59	2.23	100
TCWL02*T2N4	2.4	10,5	15	10.50	0.07	790	2.24	51	2.27	68
TCWL02*T2N7	2.7	10,5	16	10.40	0.12	640	2.23	42	2.25	61
TCWL02*T3N3	3.3	10,5,2	19	7.00	0.06	840	3.10	65	3.12	87
TCWL02*T3N6	3.6	10,5,2	19	6.80	0.06	840	3.56	45	3.62	71
TCWL02*T3N9	3.9	10,5,2	19	5.80	0.06	840	3.89	50	4.00	75
TCWL02*T4N3	4.3	10,5,2	18	6.00	0.09	700	4.19	47	4.30	71
TCWL02*T4N7	4.7	10,5,2	15	4.70	0.13	640	4.55	48	4.68	68
TCWL02*T5N1	5.1	10,5,2	20	4.80	0.08	800	5.15	56	5.25	82
TCWL02*T5N6	5.6	10,5,2	20	4.80	0.08	760	5.16	54	5.28	81
TCWL02*T6N2	6.2	10,5,2	20	4.80	0.08	760	6.16	52	6.37	76
TCWL02*T6N8	6.8	10,5,2	20	4.80	0.08	680	6.56	63	6.93	78
TCWL02*T7N5	7.5	10,5,2	22	4.80	0.10	680	7.91	60	8.22	88
TCWL02*T8N2	8.2	10,5,2	22	4.40	0.10	680	8.50	57	8.85	84
TCWL02*T8N7	8.7	10,5,2	18	4.10	0.20	480	8.78	54	9.21	73
TCWL02*T9N0	9.0	10,5,2	22	4.16	0.10	680	9.07	62	9.53	78
TCWL02*T9N5	9.5	10,5,2	18	4.00	0.20	480	9.42	54	9.98	69
TCWL02*T10N	10	10,5,2	21	3.90	0.19	480	9.80	50	10.10	67
TCWL02*T11N	11	10,5,2	24	3.68	0.12	640	10.70	52	11.20	78
TCWL02*T12N	12	10,5,2	24	3.60	0.12	640	11.90	53	12.70	71
TCWL02*T13N	13	10,5,2	24	3.45	0.21	440	13.40	51	14.60	57
TCWL02*T15N	15	10,5,2	24	3.28	0.17	560	14.60	55	15.50	77
TCWL02*T16N	16	10,5,2	24	3.10	0.22	560	16.60	46	18.80	47
TCWL02*T18N	18	10,5,2	24	3.10	0.23	420	18.30	57	20.28	62
TCWL02*T19N	19	10,5,2	24	3.04	0.20	480	19.10	50	21.10	67
TCWL02*T20N	20	10,5,2	25	3.00	0.25	420	20.70	52	23.66	53
TCWL02*T22N	22	10,5,2	25	2.80	0.30	400	23.20	53	26.75	53

Continued on the following page. ↘



RF Inductor

Continued from the preceding page.

Part Number	Inductance(nH) @ 250MHz	Tolerance (%)	Q (min)	SRF (GHz)(min)	DCR(Ω) (max)	IDC (mA)	900MHz		1.7GHz	
TCWL02*T23N	23	10,5,2	22	2.72	0.30	400	23.80	49	26.90	64
TCWL02*T24N	24	10,5,2	25	2.70	0.30	400	25.10	51	29.50	50
TCWL02*T27N	27	10,5,2	24	2.48	0.30	400	28.70	49	33.50	63
TCWL02*T30N	30	10,5,2	25	2.35	0.35	400	31.10	46	38.50	39
TCWL02*T33N	33	10,5,2	24	2.35	0.35	400	34.90	31	41.74	32
TCWL02*T36N	36	10,5,2	24	2.32	0.44	320	39.50	44	48.40	53
TCWL02*T39N	39	10,5,2	25	2.10	0.55	200	41.70	47	50.23	45
TCWL02*T40N	40	10,5,2	24	2.24	0.44	320	39.00	44	47.40	33
TCWL02*T43N	43	10,5,2	25	2.03	0.81	100	45.80	46	61.55	34
TCWL02*T47N	47	10,5,2	20	2.10	0.83	150	50.00	38	-	-
TCWL02*T51N	51	10,5,2	25	1.75	0.82	100	-	-	-	-
TCWL02*T56N	56	10,5,2	22	1.76	0.97	100	-	-	-	-
TCWL02*T68N	68	10,5,2	22	1.62	1.12	100	-	-	-	-

Note: Working Temperature Range: -40°C ~ 125°C

Standard Electrical Specifications for 0603 Wire Wound Chip Inductors / Standard

Part Number	Inductance (nH)	Tolerance (%)	Q (min)	SRF (GHz) (min)	DCR (Ω) (max)	IDC (mA)	900MHz		1.7GHz		Color Code
							L	Q	L	Q	
Test Freq. @ 250MHz											
TCWL03*T1N6	1.6	10,5	24	12.5	0.030	700	1.53	35	1.58	55	Blue
TCWL03*T1N8	1.8	10,5	16	12.5	0.045	700	1.63	35	1.66	50	Black
TCWL03*T2N2	2.2	10,5	20	6.00	0.100	700	2.18	41	2.20	64	White
TCWL03*T2N7	2.7	10,5	16	>4.00	0.140	700	2.39	25	2.44	55	Yellow
TCWL03*T3N3	3.3	10,5,2	22	>6.00	0.080	700	3.35	47	3.40	65	Red
TCWL03*T3N6	3.6	10,5,2	22	5.80	0.063	700	3.53	49	3.58	65	Violet
TCWL03*T3N9	3.9	10,5,2	22	>6.00	0.080	700	3.95	49	3.96	67	Brown
TCWL03*T4N3	4.3	10,5,2	22	5.80	0.063	700	4.32	49	4.43	67	Orange
TCWL03*T4N5	4.5	10,5,2	20	5.80	0.120	700	4.74	55	4.87	92	Gray
TCWL03*T4N7	4.7	10,5,2	20	5.80	0.120	700	4.65	53	4.80	67	Violet
TCWL03*T5N1	5.1	10,5,2	20	5.80	0.160	700	5.13	47	5.36	56	Green
TCWL03*T5N6	5.6	10,5,2	20	5.80	0.170	700	5.53	56	5.86	77	Yellow
TCWL03*T6N2	6.2	10,5,2	25	5.80	0.110	700	6.28	60	6.40	85	Black
TCWL03*T6N3	6.3	10,5,2	25	5.80	0.110	700	6.67	41	6.86	61	Black
TCWL03*T6N8	6.8	10,5,2	27	5.80	0.110	700	6.75	60	7.10	81	Red
TCWL03*T7N5	7.5	10,5,2	28	4.80	0.106	700	7.70	60	7.82	65	Brown
TCWL03*T8N2	8.2	10,5,2	27	4.80	0.110	700	8.25	64	8.40	81	Green
TCWL03*T8N7	8.7	10,5,2	28	4.60	0.109	700	8.86	62	9.32	58	Yellow
TCWL03*T9N1	9.1	10,5,2	35	4.80	0.130	700	9.20	70	9.70	80	Black
TCWL03*T9N5	9.5	10,5,2	28	5.40	0.135	700	9.70	59	9.92	61	Blue
TCWL03*T10N	10.0	10,5,2	31	4.80	0.130	700	10.0	66	10.6	83	Orange
TCWL03*T11N	11.0	10,5,2	31	4.00	0.086	700	11.3	53	12.1	56	Gray

Continued on the following page. ↘





RF Inductor

Continued from the preceding page.

Part Number	Inductance (nH)	Tolerance (%)	Q (min)	SRF (GHz) (min)	DCR (Ω) (max)	IDC (mA)	900MHz		1.7GHz		Color Code
							L	Q	L	Q	
Test Freq. @ 250MHz											
TCWL03*T12N	12.0	10,5,2	35	4.00	0.130	700	12.3	72	13.5	83	Yellow
TCWL03*T15N	15.0	10,5,2	35	4.00	0.170	700	15.4	64	16.8	89	Green
TCWL03*T16N	16.0	10,5,2	35	3.30	0.110	700	16.5	55	18.0	52	White
TCWL03*T17N	17.0	10,5,2	35	3.20	0.170	700	17.6	56	19.4	44	Red
TCWL03*T18N	18.0	10,5,2	35	3.10	0.170	700	18.7	70	21.4	69	Blue
TCWL03*T20N	20.0	10,5,2	40	3.00	0.190	700	20.7	80	23.5	30	Green
TCWL03*T22N	22.0	10,5,2	38	3.00	0.190	700	22.8	73	26.1	71	Violet
TCWL03*T23N	23.0	10,5,2	38	2.85	0.190	700	24.1	71	28.0	71	Orange
TCWL03*T24N	24.0	10,5,2	36	2.80	0.130	700	25.7	45	30.9	40	Black
TCWL03*T27N	27.0	10,5,2	40	2.80	0.220	600	29.2	74	34.6	65	Gray
TCWL03*T30N	30.0	10,5,2	37	2.80	0.150	600	31.4	47	39.8	28	Brown
TCWL03*T33N	33.0	10,5,2	40	2.30	0.220	600	36.0	67	49.5	42	White
TCWL03*T36N	36.0	10,5,2	37	2.30	0.250	600	39.1	47	48.9	24	Red
TCWL03*T39N	39.0	10,5,2	40	2.20	0.250	600	42.7	60	60.2	40	Black
Test Freq. @ 200MHz											
TCWL03*T43N	43.0	10,5,2	38	2.00	0.280	600	46.9	44	60.3	21	Orange
TCWL03*T47N	47.0	10,5,2	38	2.00	0.280	600	52.2	62	77.2	35	Brown
TCWL03*T51N	51.0	10,5,2	35	1.90	0.280	600	55.5	69	82.2	34	Blue
TCWL03*T56N	56.0	10,5,2	38	1.90	0.310	600	62.5	56	97.0	26	Red
TCWL03*T62N	62.0	10,5,2	37	1.80	0.340	600	68.0	40	110	10	Gray
TCWL03*T68N	68.0	10,5,2	37	1.70	0.340	600	80.5	54	168	21	Orange
Test Freq. @ 150MHz											
TCWL03*T72N	72.0	10,5,2	34	1.70	0.490	400	82.0	53	135	20	Yellow
TCWL03*T82N	82.0	10,5,2	34	1.70	0.540	400	96.2	54	177	21	Green
TCWL03*T91N	91.0	10,5,2	30	1.70	0.500	400	110	50	-	-	Brown
TCWL03*TR10	100	10,5,2	34	1.40	0.580	400	124	49	-	-	Blue
TCWL03*TR11	110	10,5,2	32	1.35	0.610	300	138	43	-	-	Violet
TCWL03*TR12	120	10,5,2	32	1.30	0.650	300	166	39	-	-	Gray
TCWL03*TR13	130	10,5,2	30	1.40	0.720	300	185	60	-	-	White
Test Freq. @ 100MHz											
TCWL03*TR14	140	10,5,2	28	1.30	0.870	280	190	80	-	-	Blue
TCWL03*TR15	150	10,5,2	32	1.30	0.950	280	230	25	-	-	White
TCWL03*TR16	160	10,5,2	25	1.30	1.400	280	215	-	-	-	Yellow
TCWL03*TR18	180	10,5,2	25	1.25	1.400	250	305	22	-	-	Black
TCWL03*TR22	220	10,5,2	25	1.20	1.600	250	377	-	-	-	Brown
TCWL03*TR26	260	10,5,2	25	1.00	2.000	200	469	-	-	-	Violet
TCWL03*TR27	270	10,5,2	25	0.90	2.100	200	-	-	-	-	Red
TCWL03*TR28	280	10,5,2	25	1.00	2.400	100	-	-	-	-	Green
TCWL03*TR30	300	10,5,2	25	0.75	2.500	150	-	-	-	-	Orange
TCWL03*TR33	330	10,5,2	25	0.90	3.800	100	-	-	-	-	Blue
TCWL03*TR39	390	10,5,2	25	0.90	4.350	100	-	-	-	-	Yellow

Note: Working Temperature Range: -40°C ~ 125°C



RF Inductor

► Standard Electrical Specifications for 0805 Wire Wound Chip Inductors / Standard

Part Number	Inductance (nH)	Tolerance (%)	Q (min)	SRF (GHz)(min)	DCR (Ω)(max)	IDC (mA)	Color Code
TCWL05*T2N7	2.7 @ 250MHz	10,5	80 @ 1500MHz	7.900	0.06	800	Brown
TCWL05*T2N8	2.8 @ 250MHz	10,5	80 @ 1500MHz	7.900	0.06	800	Gray
TCWL05*T3N0	3.0 @ 250MHz	10,5	65 @ 1500MHz	7.900	0.06	800	White
TCWL05*T3N3	3.3 @ 250MHz	10,5	50 @ 1500MHz	6.000	0.08	600	Black
TCWL05*T5N6	5.6 @ 250MHz	10,5	65 @ 1000MHz	5.500	0.08	600	Orange
TCWL05*T6N2	6.2 @ 250MHz	10,5	50 @ 1000MHz	5.500	0.11	600	Green
TCWL05*T6N8	6.8 @ 250MHz	10,5	50 @ 1000MHz	5.500	0.11	600	Brown
TCWL05*T7N5	7.5 @ 250MHz	10,5	50 @ 1000MHz	4.500	0.14	600	Green
TCWL05*T8N2	8.2 @ 250MHz	10,5	50 @ 1000MHz	4.700	0.12	600	Red
TCWL05*T8N7	8.7 @ 250MHz	10,5	50 @ 1000MHz	3.900	0.21	400	White
TCWL05*T10N	10.0 @ 250MHz	10,5,2	60 @ 500MHz	4.200	0.10	600	Blue
TCWL05*T12N	12.0 @ 250MHz	10,5,2	50 @ 500MHz	4.000	0.15	600	Orange
TCWL05*T15N	15.0 @ 250MHz	10,5,2	50 @ 500MHz	3.400	0.17	600	Yellow
TCWL05*T18N	18.0 @ 250MHz	10,5,2	50 @ 500MHz	3.300	0.20	600	Green
TCWL05*T22N	22.0 @ 250MHz	10,5,2	55 @ 500MHz	2.600	0.22	500	Blue
TCWL05*T24N	24.0 @ 250MHz	10,5,2	50 @ 500MHz	2.000	0.22	500	Gray
TCWL05*T27N	27.0 @ 250MHz	10,5,2	55 @ 500MHz	2.500	0.25	500	Violet
TCWL05*T33N	33.0 @ 250MHz	10,5,2	60 @ 500MHz	2.050	0.27	500	Gray
TCWL05*T36N	36.0 @ 250MHz	10,5,2	55 @ 500MHz	1.700	0.27	500	Orange
TCWL05*T39N	39.0 @ 250MHz	10,5,2	60 @ 500MHz	2.000	0.29	500	White
TCWL05*T43N	43.0 @ 200MHz	10,5,2	60 @ 500MHz	1.650	0.34	500	Yellow
TCWL05*T47N	47.0 @ 200MHz	10,5,2	60 @ 500MHz	1.650	0.31	500	Black
TCWL05*T56N	56.0 @ 200MHz	10,5,2	60 @ 500MHz	1.550	0.34	500	Brown
TCWL05*T68N	68.0 @ 200MHz	10,5,2	60 @ 500MHz	1.450	0.38	500	Red
TCWL05*T72N	72.0 @ 150MHz	10,5,2	65 @ 500MHz	1.400	0.40	500	Green
TCWL05*T82N	82.0 @ 150MHz	10,5,2	65 @ 500MHz	1.300	0.42	400	Orange
TCWL05*T91N	91.0 @ 150MHz	10,5,2	65 @ 500MHz	1.200	0.48	400	Black
TCWL05*TR10	100 @ 150MHz	10,5,2	65 @ 500MHz	1.200	0.46	400	Yellow
TCWL05*TR11	110 @ 150MHz	10,5,2	50 @ 250MHz	1.000	0.48	400	Brown
TCWL05*TR12	120 @ 150MHz	10,5,2	50 @ 250MHz	1.100	0.51	400	Green
TCWL05*TR15	150 @ 100MHz	10,5,2	50 @ 250MHz	0.920	0.56	400	Blue
TCWL05*TR18	180 @ 100MHz	10,5,2	50 @ 250MHz	0.870	0.64	400	Violet
TCWL05*TR20	200 @ 100MHz	10,5,2	50 @ 250MHz	0.860	0.66	400	Orange
TCWL05*TR22	220 @ 100MHz	10,5,2	50 @ 250MHz	0.850	0.70	400	Gray
TCWL05*TR24	240 @ 100MHz	10,5,2	44 @ 250MHz	0.690	1.00	350	Red
TCWL05*TR25	250 @ 100MHz	10,5,2	45 @ 250MHz	0.680	1.00	350	Green
TCWL05*TR27	270 @ 100MHz	10,5,2	48 @ 250MHz	0.650	1.00	350	White
TCWL05*TR30	300 @ 100MHz	10,5,2	48 @ 250MHz	0.620	1.20	330	Yellow
TCWL05*TR33	330 @ 100MHz	10,5,2	48 @ 250MHz	0.600	1.40	310	Black
TCWL05*TR36	360 @ 100MHz	10,5,2	48 @ 250MHz	0.580	1.45	300	Green
TCWL05*TR39	390 @ 100MHz	10,5,2	48 @ 250MHz	0.560	1.50	290	Brown

Continued on the following page. ↘



RF Inductor

Continued from the preceding page.

Part Number	Inductance (nH)	Tolerance (%)	Q (min)	SRF (GHz)(min)	DCR (Ω)(max)	IDC (mA)	Color Code
TCWL05*TR43	430 @ 50MHz	10,5,2	33 @ 100MHz	0.430	1.70	230	Blue
TCWL05*TR47	470 @ 50MHz	10,5,2	33 @ 100MHz	0.375	1.70	220	Red
TCWL05*TR56	560 @ 25MHz	10,5,2	23 @ 50MHz	0.340	1.90	210	Orange
TCWL05*TR60	600 @ 25MHz	10,5,2	23 @ 50MHz	0.260	1.60	450	White
TCWL05*TR62	620 @ 25MHz	10,5,2	23 @ 50MHz	0.220	2.20	210	Yellow
TCWL05*TR68	680 @ 25MHz	10,5,2	23 @ 50MHz	0.200	2.20	190	Green
TCWL05*TR75	750 @ 25MHz	10,5,2	23 @ 50MHz	0.200	2.30	180	Blue
TCWL05*TR82	820 @ 25MHz	10,5,2	23 @ 50MHz	0.200	2.35	180	Violet
TCWL05*T1R0	1000 @ 25MHz	10,5,2	20 @ 50MHz	0.100	2.50	170	Gray
TCWL05*T1R2	1200 @ 7.9MHz	10,5,2	18 @ 25MHz	0.100	2.50	170	White
TCWL05*T1R5	1500 @ 7.9MHz	10,5,2	16 @ 25MHz	0.100	2.50	170	Black
TCWL05*T1R8	1800 @ 7.9MHz	10,5,2	16 @ 7.9MHz	0.080	2.50	170	Brown
TCWL05*T2R2	2200 @ 7.9MHz	10,5,2	16 @ 7.9MHz	0.060	2.70	160	Red
TCWL05*T2R7	2700 @ 7.9MHz	10,5,2	16 @ 7.9MHz	0.050	2.95	150	Orange

Note: Working Temperature Range: -40°C ~ 125°C

Standard Electrical Specifications for 1206 Wire Wound Chip Inductors / Standard

Part Number	Inductance (nH)	Tolerance (%)	Q (min)	SRF(GHz) (min)	DCR(Ω) (max)	IDC (mA)	Color Code
TCWL06*T6N8	6.8 @ 100MHz	10,5	30 @ 300MHz	5.50	0.07	1000	Brown
TCWL06*T10N	10.0 @ 100MHz	10,5	40 @ 300MHz	4.00	0.08	1000	Red
TCWL06*T12N	12.0 @ 100MHz	10,5	40 @ 300MHz	3.20	0.08	1000	Orange
TCWL06*T15N	15.0 @ 100MHz	10,5	40 @ 300MHz	3.20	0.10	1000	Yellow
TCWL06*T18N	18.0 @ 100MHz	10,5	50 @ 300MHz	2.80	0.10	1000	Green
TCWL06*T22N	22.0 @ 100MHz	10,5	50 @ 300MHz	2.20	0.10	1000	Blue
TCWL06*T24N	24.0 @ 100MHz	10,5	50 @ 300MHz	2.00	0.10	1000	Red
TCWL06*T27N	27.0 @ 100MHz	10,5,2	50 @ 300MHz	1.80	0.11	1000	Violet
TCWL06*T33N	33.0 @ 100MHz	10,5,2	55 @ 300MHz	1.80	0.11	1000	Gray
TCWL06*T39N	39.0 @ 100MHz	10,5,2	55 @ 300MHz	1.80	0.12	1000	White
TCWL06*T47N	47.0 @ 100MHz	10,5,2	55 @ 300MHz	1.50	0.13	1000	Black
TCWL06*T56N	56.0 @ 100MHz	10,5,2	55 @ 300MHz	1.45	0.14	1000	Brown
TCWL06*T62N	62.0 @ 100MHz	10,5,2	55 @ 300MHz	1.20	0.20	1000	Violet
TCWL06*T68N	68.0 @ 100MHz	10,5,2	55 @ 300MHz	1.20	0.26	950	Red
TCWL06*T82N	82.0 @ 100MHz	10,5,2	55 @ 300MHz	1.20	0.21	920	Orange
TCWL06*T91N	91.0 @ 100MHz	10,5,2	55 @ 300MHz	1.10	0.24	900	White
TCWL06*TR10	100 @ 100MHz	10,5,2	55 @ 300MHz	1.10	0.26	850	Yellow
TCWL06*TR12	120 @ 100MHz	10,5,2	55 @ 300MHz	0.75	0.26	800	Green
TCWL06*TR15	150 @ 100MHz	10,5,2	60 @ 300MHz	0.95	0.31	750	Blue
TCWL06*TR18	180 @ 50MHz	10,5,2	55 @ 300MHz	0.90	0.43	700	Violet
TCWL06*TR22	220 @ 50MHz	10,5,2	55 @ 300MHz	0.76	0.50	670	Gray
TCWL06*TR27	270 @ 50MHz	10,5,2	55 @ 300MHz	0.74	0.56	630	White
TCWL06*TR30	300 @ 50MHz	10,5,2	50 @ 150MHz	0.68	0.60	600	Green

Continued on the following page. ↘



RF Inductor

Continued from the preceding page.

Part Number	Inductance (nH)	Tolerance (%)	Q (min)	SRF(GHz) (min)	DCR(Ω) (max)	IDC (mA)	Color Code
TCWL06*TR33	330 @ 50MHz	10,5,2	45 @ 150MHz	0.65	0.62	590	Black
TCWL06*TR36	360 @ 50MHz	10,5,2	45 @ 150MHz	0.60	0.65	550	Blue
TCWL06*TR39	390 @ 50MHz	10,5,2	45 @ 150MHz	0.60	0.75	530	Brown
TCWL06*TR47	470 @ 50MHz	10,5,2	45 @ 150MHz	0.55	1.30	490	Red
TCWL06*TR56	560 @ 35MHz	10,5,2	45 @ 150MHz	0.47	1.34	460	Orange
TCWL06*TR62	620 @ 35MHz	10,5,2	45 @ 150MHz	0.47	1.58	460	Gray
TCWL06*TR68	680 @ 35MHz	10,5,2	45 @ 150MHz	0.45	1.58	430	Yellow
TCWL06*TR75	750 @ 35MHz	10,5,2	45 @ 150MHz	0.44	2.25	320	White
TCWL06*TR82	820 @ 35MHz	10,5,2	45 @ 150MHz	0.42	1.82	400	Green
TCWL06*TR91	910 @ 35MHz	10,5,2	45 @ 150MHz	0.41	2.95	310	Green
TCWL06*T1R0	1000 @ 35MHz	10,5,2	45 @ 150MHz	0.40	2.80	320	Blue
TCWL06*T1R2	1200 @ 35MHz	10,5,2	45 @ 150MHz	0.38	3.20	300	Violet

Note: Working Temperature Range: -40°C ~ 125°C

► Standard Electrical Specifications for 1008 Wire Wound Chip Inductors / Standard

Part Number	Inductance (nH)	Tolerance (%)	Q (min)	SRF(GHz) (min)	DCR (Ω)(max)	IDC (mA)	Color Code
Δ TCWL08*T5N6	5.6 @ 50MHz	10,5	50 @ 1500MHz	4.000	0.15	1000	Black
Δ TCWL08*T10N	10 @ 50MHz	10,5,2	50 @ 500MHz	4.100	0.08	1000	Brown
Δ TCWL08*T12N	12 @ 50MHz	10,5,2	50 @ 500MHz	3.300	0.09	1000	Red
Δ TCWL08*T15N	15 @ 50MHz	10,5,2	50 @ 500MHz	2.500	0.11	1000	Orange
Δ TCWL08*T18N	18 @ 50MHz	10,5,2	50 @ 350MHz	2.400	0.12	1000	Yellow
Δ TCWL08*T22N	22 @ 50MHz	10,5,2	55 @ 350MHz	2.400	0.12	1000	Green
TCWL08*T24N	24 @ 50MHz	10,5,2	55 @ 350MHz	1.900	0.12	1000	Blue
Δ TCWL08*T27N	27 @ 50MHz	10,5,2	55 @ 350MHz	1.600	0.13	1000	Violet
Δ TCWL08*T33N	33 @ 50MHz	10,5,2	60 @ 350MHz	1.600	0.14	1000	Gray
Δ TCWL08*T36N	36 @ 50MHz	10,5,2	60 @ 350MHz	1.600	0.15	1000	Orange
Δ TCWL08*T39N	39 @ 50MHz	10,5,2	60 @ 350MHz	1.500	0.15	1000	White
Δ TCWL08*T47N	47 @ 50MHz	10,5,2	65 @ 350MHz	1.500	0.16	1000	Black
Δ TCWL08*T56N	56 @ 50MHz	10,5,2	65 @ 350MHz	1.300	0.18	1000	Brown
Δ TCWL08*T62N	59 @ 50MHz	10,5,2	65 @ 350MHz	1.250	0.20	1000	Blue
Δ TCWL08*T68N	68 @ 50MHz	10,5,2	65 @ 350MHz	1.300	0.20	1000	Red
TCWL08*T75N	75 @ 50MHz	10,5,2	60 @ 350MHz	1.100	0.21	1000	White
Δ TCWL08*T82N	82 @ 50MHz	10,5,2	60 @ 350MHz	1.000	0.22	1000	Orange
Δ TCWL08*TR10	100 @ 25MHz	10,5,2	60 @ 350MHz	1.000	0.56	650	Yellow
Δ TCWL08*TR12	120 @ 25MHz	10,5,2	60 @ 350MHz	0.950	0.63	650	Green
Δ TCWL08*TR15	150 @ 25MHz	10,5,2	45 @ 100MHz	0.850	0.70	580	Blue
Δ TCWL08*TR18	180 @ 25MHz	10,5,2	45 @ 100MHz	0.750	0.77	620	Violet
Δ TCWL08*TR22	220 @ 25MHz	10,5,2	45 @ 100MHz	0.700	0.84	500	Gray
Δ TCWL08*TR24	240 @ 25MHz	10,5,2	45 @ 100MHz	0.650	0.88	500	White
Δ TCWL08*TR27	270 @ 25MHz	10,5,2	45 @ 100MHz	0.600	0.91	500	Black

Continued on the following page. ↘



RF Inductor

↖ Continued from the preceding page.

Part Number	Inductance (nH)	Tolerance (%)	Q (min)	SRF(GHz) (min)	DCR (Ω)(max)	IDC (mA)	Color Code
Δ TCWL08*TR30	300 @ 25MHz	10,5,2	45 @ 100MHz	0.585	1.00	450	Brown
Δ TCWL08*TR33	330 @ 25MHz	10,5,2	45 @ 100MHz	0.570	1.05	450	Red
Δ TCWL08*TR36	360 @ 25MHz	10,5,2	45 @ 100MHz	0.530	1.10	470	Orange
Δ TCWL08*TR39	390 @ 25MHz	10,5,2	45 @ 100MHz	0.500	1.12	470	Yellow
Δ TCWL08*TR43	430 @ 25MHz	10,5,2	45 @ 100MHz	0.480	1.15	470	Green
Δ TCWL08*TR47	470 @ 25MHz	10,5,2	45 @ 100MHz	0.450	1.19	470	Blue
Δ TCWL08*TR56	560 @ 25MHz	10,5,2	45 @ 100MHz	0.415	1.33	400	Violet
Δ TCWL08*TR62	620 @ 25MHz	10,5,2	45 @ 100MHz	0.375	1.40	300	Gray
Δ TCWL08*TR68	680 @ 25MHz	10,5,2	45 @ 100MHz	0.375	1.47	400	White
Δ TCWL08*TR75	750 @ 25MHz	10,5,2	45 @ 100MHz	0.360	1.54	360	Black
Δ TCWL08*TR82	820 @ 25MHz	10,5,2	45 @ 100MHz	0.350	1.61	400	Brown
Δ TCWL08*TR91	910 @ 25MHz	10,5,2	35 @ 50MHz	0.320	1.68	380	Red
Δ TCWL08*T1R0	1000 @ 25MHz	10,5,2	35 @ 50MHz	0.290	1.75	370	Orange
Δ TCWL08*T1R2	1200 @ 7.9MHz	10,5,2	35 @ 50MHz	0.250	2.00	310	Yellow
Δ TCWL08*T1R5	1500 @ 7.9MHz	10,5,2	28 @ 50MHz	0.200	2.30	330	Green
Δ TCWL08*T1R8	1800 @ 7.9MHz	10,5,2	28 @ 50MHz	0.160	2.60	300	Blue
Δ TCWL08*T2R2	2200 @ 7.9MHz	10,5,2	28 @ 50MHz	0.160	2.80	280	Violet
Δ TCWL08*T2R7	2700 @ 7.9MHz	10,5,2	22 @ 25MHz	0.140	3.20	290	Gray
Δ TCWL08*T3R3	3300 @ 7.9MHz	10,5,2	22 @ 25MHz	0.110	3.40	290	White
Δ TCWL08*T3R9	3900 @ 7.9MHz	10,5,2	20 @ 25MHz	0.100	3.60	260	Black
Δ TCWL08*T4R7	4700 @ 7.9MHz	10,5,2	18 @ 25MHz	0.090	4.00	260	Brown
TCWL08*T5R6	5600 @ 7.9MHz	10,5,2	16 @ 7.96MHz	0.020	4.00	240	Red
TCWL08*T6R8	6800 @ 7.9MHz	10,5,2	15 @ 7.96MHz	0.040	4.90	200	Orange
TCWL08*T8R2	8200 @ 7.9MHz	10,5,2	15 @ 7.96MHz	0.025	6.00	170	Yellow
TCWL08*T100	10000 @ 2.52MHz	10,5,2	15 @ 7.96MHz	0.020	9.00	150	Green
TCWL08*T120	12000 @ 2.52MHz	10,5,2	15 @ 7.96MHz	0.018	10.5	130	Blue
TCWL08*T150	15000 @ 2.52MHz	10,5,2	15 @ 7.96MHz	0.015	11.5	120	Violet

Note: Working Temperature Range: -40°C ~ 125°C

Δ Test Methods/Instrument: Network/Spectrum Analyzer.



RF Inductor

► Standard Electrical Specifications for 0805 Wire Wound Chip Inductors / Low Profile

Part Number	Inductance(nH)	Tolerance (%)	Q(min)	SRF(GHz) (min)	DCR(Ω) (max)	IDC (mA)	Color Code
TCWL05*TL1N8	1.8 @ 250MHz	10	55 @ 1500MHz	9.40	0.03	800	Black
TCWL05*TL3N9	3.9 @ 250MHz	10,5	50 @ 1000MHz	6.10	0.06	800	Brown
TCWL05*TL4N7	4.7 @ 250MHz	10,5	50 @ 1000MHz	5.50	0.06	800	Red
TCWL05*TL6N8	6.8 @ 250MHz	10,5	50 @ 1000MHz	5.50	0.08	800	Orange
TCWL05*TL8N2	8.2 @ 250MHz	10,5	50 @ 1000MHz	4.80	0.08	800	Yellow
TCWL05*TL10N	10.0 @ 250MHz	10,5,2	55 @ 750MHz	3.30	0.08	800	Green
TCWL05*TL12N	12.0 @ 250MHz	10,5,2	55 @ 750MHz	3.80	0.10	800	Blue
TCWL05*TL15N	15.0 @ 250MHz	10,5,2	50 @ 500MHz	2.95	0.10	800	Violet
TCWL05*TL18N	18.0 @ 250MHz	10,5,2	50 @ 500MHz	3.10	0.13	800	Gray
TCWL05*TL22N	22.0 @ 250MHz	10,5,2	50 @ 500MHz	2.90	0.15	800	Whit
TCWL05*TL27N	27.0 @ 250MHz	10,5,2	50 @ 500MHz	2.45	0.23	600	Black
TCWL05*TL33N	33.0 @ 250MHz	10,5,2	50 @ 500MHz	2.35	0.28	600	Brown
TCWL05*TL39N	39.0 @ 250MHz	10,5,2	50 @ 500MHz	2.20	0.33	600	Red
TCWL05*TL47N	47.0 @ 200MHz	10,5,2	50 @ 500MHz	2.00	0.39	600	Orange
TCWL05*TL56N	56.0 @ 200MHz	10,5,2	50 @ 500MHz	1.85	0.39	500	Yellow
TCWL05*TL68N	68.0 @ 200MHz	10,5,2	50 @ 500MHz	1.50	0.40	500	Green
TCWL05*TL82N	82.0 @ 150MHz	10,5,2	50 @ 500MHz	1.50	0.44	500	Blue
TCWL05*TLR10	100.0 @ 150MHz	10,5,2	50 @ 500MHz	1.20	0.64	400	Violet
TCWL05*TLR12	120.0 @ 150MHz	10,5,2	40 @ 250MHz	1.15	0.68	300	Gray
TCWL05*TLR15	150.0 @ 150MHz	10,5,2	40 @ 250MHz	1.05	0.80	300	Whit
TCWL05*TL1R0	1000.0 @ 25MHz	10,5,2	16 @ 50MHz	0.08	2.00	220	Black

Note: Working Temperature Range: -40°C ~ 125°C

► Standard Electrical Specifications for 1008 Wire Wound Chip Inductors / Low Profile

Part Number	Inductance (nH)	Tolerance (%)	Q (min)	SRF(GHz) (min)	DCR(Ω) (max)	IDC (mA)	Color Code
TCWL08*TL4N2	4.2 @ 50MHz	10,5	42 @ 1500MHz	6.00	0.15	600	Black
TCWL08*TL6N8	6.8 @ 50MHz	10,5	50 @ 1500MHz	5.40	0.17	600	Brown
TCWL08*TL8N2	8.2 @ 50MHz	10,5	50 @ 1500MHz	5.00	0.22	600	Red
TCWL08*TL15N	15 @ 50MHz	10,5	57 @ 500MHz	3.00	0.22	600	Orange
TCWL08*TL20N	20 @ 50MHz	10,5	72 @ 500MHz	2.40	0.33	600	Yellow
TCWL08*TL27N	27 @ 50MHz	10,5	50 @ 350MHz	1.60	0.13	600	Green
TCWL08*TL30N	30 @ 50MHz	10,5	69 @ 500MHz	2.40	0.38	600	Blue
TCWL08*TL40N	40 @ 50MHz	10,5	67 @ 500MHz	2.00	0.43	600	Violet
TCWL08*TL50N	50 @ 50MHz	10,5,2	72 @ 500MHz	1.90	0.48	600	Gray
TCWL08*TL60N	60 @ 50MHz	10,5,2	75 @ 500MHz	1.80	0.52	600	White
TCWL08*TL70N	70 @ 50MHz	10,5,2	68 @ 500MHz	1.70	0.55	510	Black
TCWL08*TL80N	80 @ 50MHz	10,5,2	75 @ 500MHz	1.40	0.56	510	Brown
TCWL08*TLR56	560 @ 25MHz	10,5,2	40 @ 100MHz	0.40	1.33	400	Red

Note: Working Temperature Range: -40°C ~ 125°C





RF Inductor

► Standard Electrical Specifications for 0603 Wire Wound Chip Inductors / High Current

Part Number	Inductance (nH)	Tolerance (%)	Q (min)	SRF(GHz) (min)	DCR (Ω)(max)	IDC (mA)	Color Code
TCWL03*TH1N6	1.6 @ 250MHz	10,5	24	12.50	0.030	2400	Black
TCWL03*TH3N6	3.6 @ 250MHz	10,5	24	5.90	0.048	2300	Brown
TCWL03*TH3N9	3.9 @ 250MHz	10,5	25	5.90	0.054	2200	Red
TCWL03*TH6N8	6.8 @ 250MHz	10,5	35	5.80	0.054	2100	Orange
TCWL03*TH7N5	7.5 @ 250MHz	10,5	35	3.70	0.059	2100	Yellow
TCWL03*TH8N2	8.2 @ 250MHz	10,5	38	3.70	0.060	2000	White
TCWL03*TH10N	10.0 @ 250MHz	10,5,2	38	3.70	0.071	2000	Green
TCWL03*TH12N	12.0 @ 250MHz	10,5,2	38	3.00	0.075	2000	Blue
TCWL03*TH15N	15.0 @ 250MHz	10,5,2	38	2.80	0.080	1900	Violet
TCWL03*TH18N	18.0 @ 250MHz	10,5,2	40	2.80	0.099	1900	Gray
TCWL03*TH22N	22.0 @ 250MHz	10,5,2	42	2.40	0.099	1800	White
TCWL03*TH24N	24.0 @ 250MHz	10,5,2	42	2.40	0.105	1800	Black

Note: Working Temperature Range: -40°C ~ 125°C

► Standard Electrical Specifications for 0805 Wire Wound Chip Inductors / High Q

Part Number	Inductance (nH)	Tolerance (%)	Q (min)	SRF(GHz) (min)	DCR (Ω)(max)	IDC (mA)	Color Code
TCWL05*TH2N5	2.5 @ 250MHz	10,5	80 @ 1500MHz	6.00	0.020	1600	Black
TCWL05*TH5N6	5.6 @ 250MHz	10,5	98 @ 1500MHz	6.00	0.035	1600	Brown
TCWL05*TH6N2	6.2 @ 250MHz	10,5	88 @ 1000MHz	4.75	0.035	1600	Red
TCWL05*TH6N8	6.8 @ 250MHz	10,5	80 @ 1000MHz	4.40	0.035	1600	White
TCWL05*TH8N2	8.2 @ 250MHz	10,5	75 @ 1000MHz	3.00	0.075	1000	Gray
TCWL05*TH12N	12 @ 250MHz	10,5	80 @ 1000MHz	3.00	0.045	1600	Orange
TCWL05*TH15N	15 @ 250MHz	10,5,2	80 @ 1000MHz	2.80	0.100	1200	Black
TCWL05*TH16N	16 @ 250MHz	10,5,2	72 @ 500MHz	2.95	0.060	1500	Yellow
TCWL05*TH18N	18 @ 250MHz	10,5,2	75 @ 500MHz	2.55	0.060	1400	Green
TCWL05*TH20N	20 @ 250MHz	10,5,2	70 @ 500MHz	2.05	0.055	1400	Blue
TCWL05*TH22N	22 @ 250MHz	10,5,2	80 @ 500MHz	2.00	0.100	1200	Black
TCWL05*TH27N	27 @ 250MHz	10,5,2	75 @ 500MHz	2.00	0.070	1300	Violet
TCWL05*TH30N	30 @ 250MHz	10,5,2	65 @ 500MHz	1.95	0.095	1200	Gray
TCWL05*TH39N	39 @ 250MHz	10,5,2	65 @ 500MHz	1.60	0.110	1100	White
TCWL05*TH48N	48 @ 200MHz	10,5,2	65 @ 500MHz	1.40	0.095	1200	Black
TCWL05*TH51N	51 @ 200MHz	10,5,2	65 @ 500MHz	1.40	0.120	1000	Brown

Note: Working Temperature Range: -40°C ~ 125°C



RF Inductor

Standard Electrical Specifications for 1008 Wire Wound Chip Inductors / High Q

Part Number	Inductance (nH)	Tolerance (%)	Q (min)	SRF (GHz)(min)	DCR (Ω)(max)	IDC (mA)	Color Code
Δ TCWL08*TH3N0	3.0 @ 50MHz	10,5	70 @ 1500MHz	6.00	0.04	1600	Black
TCWL08*TH4N1	4.1 @ 50MHz	10,5	75 @ 1500MHz	6.00	0.05	1600	Brown
Δ TCWL08*TH7N8	7.8 @ 50MHz	10,5	75 @ 500MHz	3.80	0.05	1600	Red
TCWL08*TH10N	10 @ 50MHz	10,5,2	60 @ 500MHz	3.60	0.06	1600	Orange
TCWL08*TH12N	12 @ 50MHz	10,5,2	70 @ 500MHz	2.80	0.06	1500	Yellow
TCWL08*TH18N	18 @ 50MHz	10,5,2	62 @ 350MHz	2.70	0.07	1400	Green
TCWL08*TH22N	22 @ 50MHz	10,5,2	62 @ 350MHz	2.05	0.07	1400	Blue
TCWL08*TH33N	33 @ 50MHz	10,5,2	75 @ 350MHz	1.70	0.09	1300	Violet
TCWL08*TH39N	39 @ 50MHz	10,5,2	75 @ 350MHz	1.30	0.09	1300	Gray
TCWL08*TH47N	47 @ 50MHz	10,5,2	75 @ 350MHz	1.45	0.12	1200	White
TCWL08*TH56N	56 @ 50MHz	10,5,2	75 @ 350MHz	1.23	0.12	1200	Black
TCWL08*TH68N	68 @ 50MHz	10,5,2	80 @ 350MHz	1.15	0.13	1100	Brown
TCWL08*TH82N	82 @ 50MHz	10,5,2	80 @ 350MHz	1.06	0.16	1100	Red
TCWL08*THR10	100 @ 50MHz	10,5,2	52 @ 350MHz	0.82	0.16	1000	Orange

Note: Working Temperature Range: $-40^{\circ}\text{C} \sim 125^{\circ}\text{C}$

Δ Parts (3.0nH, 7.8nH) are wound on a low profile bobbin.

Wirewound Chip Inductor Packaging Quantity & Reel Specifications (Unit: mm)

Type	Emboss Plastic Tape (PCS)
TCWL08	2000
TCWL06	2000
TCWL05	2000
TCWL03	4000
TCWL02	4000

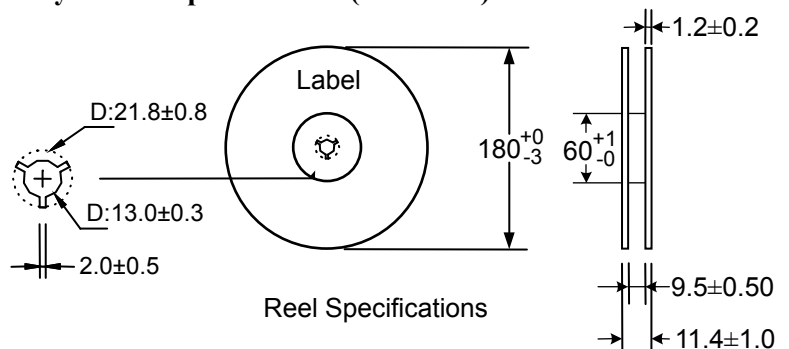

Wirewound Chip Inductor Emboss Plastic Tape Specifications (Unit: mm)

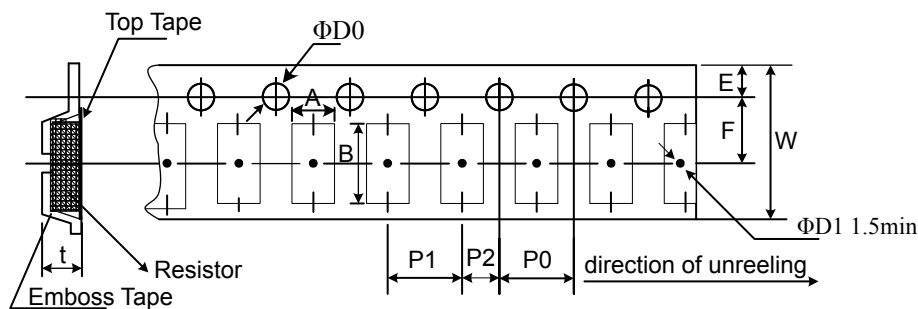

Codes	A \pm 0.10	B \pm 0.10	W \pm 0.2	E \pm 0.10	F \pm 0.1	P0 \pm 0.10	P1 \pm 0.10	P2 \pm 0.05	Φ D0 \pm 0.10	t \pm 0.05
TCWL08	2.70	2.80	8.0	1.75	3.5	4.00	4.00	2.00	1.50	2.00
TCWL06	1.95	3.50	8.0	1.75	3.5	4.00	4.00	2.00	1.50	1.50
TCWL05	1.85	2.30	8.0	1.75	3.5	4.00	4.00	2.00	1.50	1.45
TCWL03	1.12	1.85	8.0	1.75	3.5	4.00	4.00	2.00	1.50	0.96
TCWL02	0.71	1.16	8.0	1.75	3.5	4.00	2.00	2.00	1.50	0.65



RF Inductor

► Environmental Characteristics - Wirewound Chip Inductors

Electrical Performance Test

Item	Specification	Test Method
Vibration Test	Appearance: No damage L change: within $\pm 5\%$ Q change: within $\pm 10\%$	Test device shall be soldered on the substrate Oscillation Frequency: 10 to 55 to 10Hz for 1min Amplitude: 1.5mm Time: 2hrs for each axis (X, Y & Z), total 6hrs
Resistance to Soldering-Heat		Solder Temperature: $260 \pm 5^\circ\text{C}$ Immersion Time: $10 \pm 2\text{sec}$
Component Adhesion (Push Test)	1 lbs. For 0402 2 lbs. For 0603 3 lbs. For the rest	The device should be soldered ($260 \pm 5^\circ\text{C}$ for 10 seconds) to a tinned copper subs rate. A dynamiter force gauge should be applied to the side of the component. The device must with stand a minimum force of 2 or 4 pounds without a failure of adhesion on termination
Drop Test	No damage	Dropping chip by each side and each corner. Drop 10 times in total Drop height: 100cm Drop weight: 125g
Solderability Test	90% covered with solder.	Inductor shall be dipped in a melted solder bath at $235 \pm 5^\circ\text{C}$ for 5 seconds.
Resistance to Solvent Test	No damage on appearance and marking.	MIL-STD202F, Method 215D

Mechanical Performance Test

Item	Specification	Test Method
Inductance	Refer to standard electrical characteristic spec.	HP4291B
Q		HP4291B
SRF		HP8753D
DC Resistance RDC		Micro-Ohm meter (Gom-801G)
Rated Current IDC		Applied the current to coils, The inductance change should be less than 10% to initial value
Over Load Test	Inductors shall have no evidence of electrical and mechanical damage	Applied 2 times of rated allowed DC current to inductor for a period of 5 minute
Withstanding Voltage Test	Inductors shall be no evidence of electrical and mechanical damage.	AC voltage of 500 VAC applied between inductors terminal and case for 1 minute.
Insulation Resistance Test	1000M ohm min	100 VDC applied between inductor terminal and case





RF Inductor

Climatic Test

Item	Specification	Test Method															
Temperature Characteristic	Appearance: No damage L change: within $\pm 10\%$ Q change: within $\pm 20\%$	-40°C~+125°C															
Humidity Resistance		Temperature: 40 ± 2 °C Relative Humidity: 90~95% Time: 96hrs ± 2 hrs Measured after exposure in the room condition for 2hrs															
Low Temperature Storage Test		Temperature: -40 ± 2 °C Time: 48 ± 2 hrs Inductors are tested after 1 hour at room temperature															
Thermal Shock Test		One cycle: <table border="1"> <thead> <tr> <th>Step</th> <th>Temperature (°C)</th> <th>time (min)</th> </tr> </thead> <tbody> <tr> <td>1</td> <td>-25± 3</td> <td>30</td> </tr> <tr> <td>2</td> <td>25± 2</td> <td>15</td> </tr> <tr> <td>3</td> <td>85± 3</td> <td>30</td> </tr> <tr> <td>4</td> <td>25± 2</td> <td>15</td> </tr> </tbody> </table>	Step	Temperature (°C)	time (min)	1	-25 ± 3	30	2	25 ± 2	15	3	85 ± 3	30	4	25 ± 2	15
Step		Temperature (°C)	time (min)														
1		-25 ± 3	30														
2	25 ± 2	15															
3	85 ± 3	30															
4	25 ± 2	15															
High Temperature Storage Test	Total: 5 cycles Temperature: 125 ± 2 °C Time: 48 ± 2 hrs Measured after exposure in the room condition for 1hr																
High Temperature Load Life Test	There should be no evidence of short of open circuit. Temperature: 85 ± 2 °C Time: 1000 ± 12 hrs Load: Allowed DC current																
Humidity Load Life	Temperature: 40 ± 2 °C Relative Humidity: 90~95% Time: 1000 ± 12 hrs Load: Allowed DC current																

Note: Storage Temperature: 25 ± 3 °C; Humidity < 80%RH

► How to Order

TCWL	08	J	T	L	1N6
①	②	③	④	⑤	⑥

① Wire Wound Chip Inductor

② Dimensions(L×W)(mm)

Code	Dimensions	EIA
02	1.00×0.50	0402
03	1.60×0.80	0603
05	2.00×1.20	0805
06	3.20×1.60	1206
08	2.50×2.00	1008

③ Resistance Tolerance

Code	Tolerance
G	$\pm 2\%$
J	$\pm 5\%$
K	$\pm 10\%$
M	$\pm 20\%$

④ Packaging : T (Taping Reel)

⑤ Design code

Code	Design code
	Standard Inductor
L	Low Profile Inductor
H	High Current and High Q

⑥ Inductance

Code	Inductance
1N6	1.6nH
82N	82nH
R27	270nH
1R0	1000nH
100	10000nH